

CONTINENTAL AEROSPACE TECHNOLOGIES™
CRITICAL SERVICE BULLETIN

COMPLIANCE NECESSARY TO MAINTAIN SAFETY

CATEGORY 2
CSB23-04

TECHNICAL PORTIONS
FAA APPROVED

- SUBJECT:** Hartzell Engine Technologies (HET) Alert Service Bulletin (ASB) No. 097
- PURPOSE:** To notify owners, operators, distributors, and maintenance facilities of inspection criteria for affected Hartzell alternators
- COMPLIANCE:** Compliance may be required prior to further flight. Reference attached HET ASB No. 097.
- MODELS**
- AFFECTED:** O-200-D engine models equipped with Continental Part No. 657377, or engines modified by the installation of ER14-50 STC conversion kit or engines equipped with C14-50, C14-50A and EX14-50 alternator installation kits.

Listed Continental engine models may have been equipped with affected Hartzell Engine Technologies alternator models from the Continental factory or as Continental-supplied service spares. Additional Continental engine models may have affected Hartzell Engine Technologies alternator models installed under authority of Aircraft Type Design, PMA, or STC not controlled by Continental Aerospace Technologies.

I. GENERAL INFORMATION

Hartzell Engine Technologies LLC (HET) has issued Alert Service Bulletin (ASB) No. 097 requiring inspection of the alternator mounting flange for Plane Power 15-1010 and 15-1014 alternators shipped between 01 January 2019 and 01 January 2023. Continental Alternator Part No. 657377 is the same as Plane Power 15-1010 except for the data plate - HET serial numbers in ASB No. 097 apply. Reference HET ASB No. 097 for the applicable alternators serial number(s).

Continental Aerospace Technologies™ (Continental®) recommends compliance with HET Alert Service Bulletin (ASB) No. 097.

II. WARRANTY

Direct all questions regarding actions required by the attached Alert Service Bulletin to:

Hartzell Engine Technologies LLC
2900 Selma Highway
Montgomery, AL 36108
Phone: +1-334-386-5441
FAX: +1-334-386-5410
E-mail: techsupport@HartzellEngineTech.com

ISSUED
2023/09/13

REVISED
--



DOC NO REVISION
CSB23-04

PAGE
1 of 2

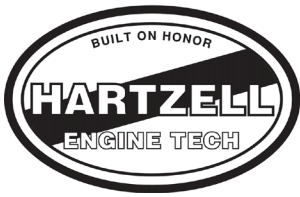

2900 Selma Highway
Montgomery, AL 36108 USA
Tel: 334-386-5400 Fax: 334-386-5450

Alert Service Bulletin

Alert Service Bulletin No. 097

Alternator Mounting Flange Inspection

1. Planning Information

A. Effectivity

- (1) Plane Power 15-1010 and 15-1014 series alternators manufactured by Hartzell Engine Tech LLC (HET) and shipped between 01/01/2019 and 01/01/2023 are affected by this Alert Service Bulletin (ASB).
- (2) All alternators using the ER14-50 STC conversion kit, and the C14-50, C14-50A, and EX14-50 alternator installation kits are affected by this ASB.
 - (a) Refer to Table-1 for engine/aircraft effectivity.

NOTE: Table-1 is for reference only and is not an all-inclusive list of aircraft affected by this ASB. It is the responsibility of the owner/operator to verify whether an affected alternator may be installed.

(b) Serial numbers affected:

- 1) Serial numbers H-T010001 thru H-X012176 are affected by this ASB.

a) Serial Number Identification for H-T thru H-X:

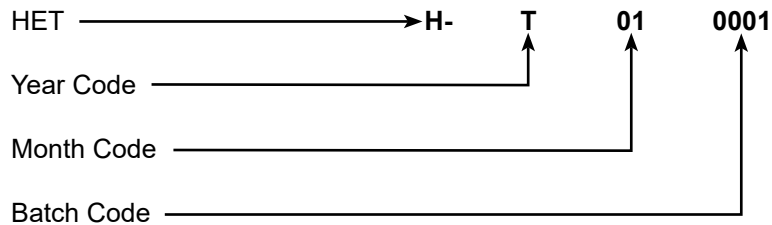

Example above: T=2019, 01=January, 0001=first unit of the month (batch). The year code advances one letter in alphabetical order for each succeeding year. X012176: X=2023, 01=January.

- b) Serial Numbers H-1010001 thru H-1019999 are affected by this ASB.

Serial numbers represented by the H-1 numbering scheme are parts manufactured in January of 2021.

WARNING:

DO NOT USE OBSOLETE OR OUTDATED INFORMATION. PERFORM ALL INSPECTIONS OR WORK IN ACCORDANCE WITH THE MOST RECENT REVISION OF THIS ALERT SERVICE BULLETIN. INFORMATION CONTAINED HEREIN MAY BE SIGNIFICANTLY CHANGED FROM EARLIER REVISIONS. FAILURE TO COMPLY WITH THIS ALERT SERVICE BULLETIN OR THE USE OF OBSOLETE INFORMATION MAY CREATE AN UNSAFE CONDITION THAT MAY RESULT IN DEATH, SERIOUS BODILY INJURY, AND/OR SUBSTANTIAL PROPERTY DAMAGE. REFER TO WWW.PLANEPOWER.AERO FOR THE MOST RECENT REVISION LEVEL OF THIS ALERT SERVICE BULLETIN.

Alert Service Bulletin

Alert Service Bulletin No. 097

Alternator Mounting Flange Inspection

B. Concurrent Requirements

- (1) None

C. Reason

- (1) Hartzell Engine Tech has discovered that alternator P/Ns referenced in 1.A. may experience a reduction in clamping force at the joint between the alternator drive end housing (1) and mounting flange (3).
 - (a) Loss of alternator mounting flange clamping force may result in loss of engine oil and/or unexpected loss of engine power.
- (2) This ASB is to advise the field of a known condition and to supply inspection criteria to identify affected alternators.

D. Description

- (1) This Alert Service Bulletin provides Instructions for Continued Airworthiness (ICA).

E. Compliance

- (1) **IMMEDIATE:** If a loss of alternator output or erratic output indication occurs during flight, land as soon as practicable while closely monitoring engine oil temperature and pressure. Comply with this ASB prior to further flight.
- (2) **Prior to Next Flight:**
 - (a) If affected alternator has less than one-hundred (100) engine-hours time-in-service:
 - 1) Inspect the underside of the aircraft for presence of excessive amounts of oil. Gain access to the alternator and inspect for engine oil leaks and/or a loose connection between the alternator drive end housing (1) and alternator mounting flange (3). Physically lift the rear of the alternator by hand and visually inspect for relative movement between the alternator drive end housing (1) and alternator mounting flange (3).
 - a) If a loose condition or oil leak is **not** found:
 - 1: Repeat inspection each twenty-five (25) engine-hours time-in-service thereafter, not to exceed one-hundred (100) hours engine time-in-service or twelve (12) calendar months from the effective date of this ASB, whichever occurs first.
 - b) If a loose condition or oil leak **is** found:
 - 1: Repair or replace the alternator prior to next flight. See Section 3.B.2.
 - (b) If affected alternator has greater than one-hundred (100) engine-hours time-in-service, regardless of Section 2.A findings:
 - 1) Repair or replace alternator in accordance with Section 3., Accomplishment Instructions.
 - (3) For affected alternators in inventory, return within 30 days from the original issue date of this Alert Service Bulletin or prior to installation, whichever occurs first.
 - (4) Repair or replacement of an affected alternator in accordance with the Section 3, Accomplishment Instructions, is the terminating action for this Alert Service Bulletin.

Alert Service Bulletin

Alert Service Bulletin No. 097

Alternator Mounting Flange Inspection

(5) One-Time-Flight

- (a) If a loose condition or oil leak is **not** discovered during 1.E.(2) above, regardless of time in service, it is permissible to complete one (1) flight up to six (6) hours in duration to reach a qualified repair station capable of the Accomplishment Instructions of this ASB.

F. Approval

- (1) FAA acceptance has been obtained on technical data in this publication that affects type design.

G. Manpower

- (1) Labor is negligible for identification and inspection when performed in conjunction with regularly scheduled maintenance required by the engine/aircraft manufacturer.
- (2) Up to one and a half (1.5) hours labor required for removal and installation of the alternator.

H. References

- (1) Applicable aircraft POH or AFM.
- (2) Aircraft maintenance manual (as applicable).
- (3) Engine Service Instructions or maintenance manual (as applicable).
- (4) Continental Aerospace Technologies' M-0 manual, *Standard Practice Maintenance Manual for Spark Ignited Engines*.

I. Other Publications Affected

- (1) None

J. Weight and Balance

- (1) No Change

2. Material Required

A. For alternator repair

- (1) Parts
 - (a) 3x Flange Bolts (3) - Zinc plated class 12.9 18mm long M6 socket head cap screw (SHCS).
 - (b) 1x O-Ring (2) size 42.8x2mm Shore A 70-80 FKM - If required.
 - (c) 1x Oil Seal (5) P/N 11-1026 - If required.
 - (d) 1x Alternator Gasket - Refer to the aircraft/engine maintenance manual for proper part number.
 - (e) 1x Mounting Flange (3) P/N 11-1025 - If required.
 - (f) LOCTITE® 272 threadlocker.

B. For alternator replacement

- (1) One new or overhauled alternator of part number removed not affected by this ASB.

Alert Service Bulletin

Alert Service Bulletin No. 097

Alternator Mounting Flange Inspection

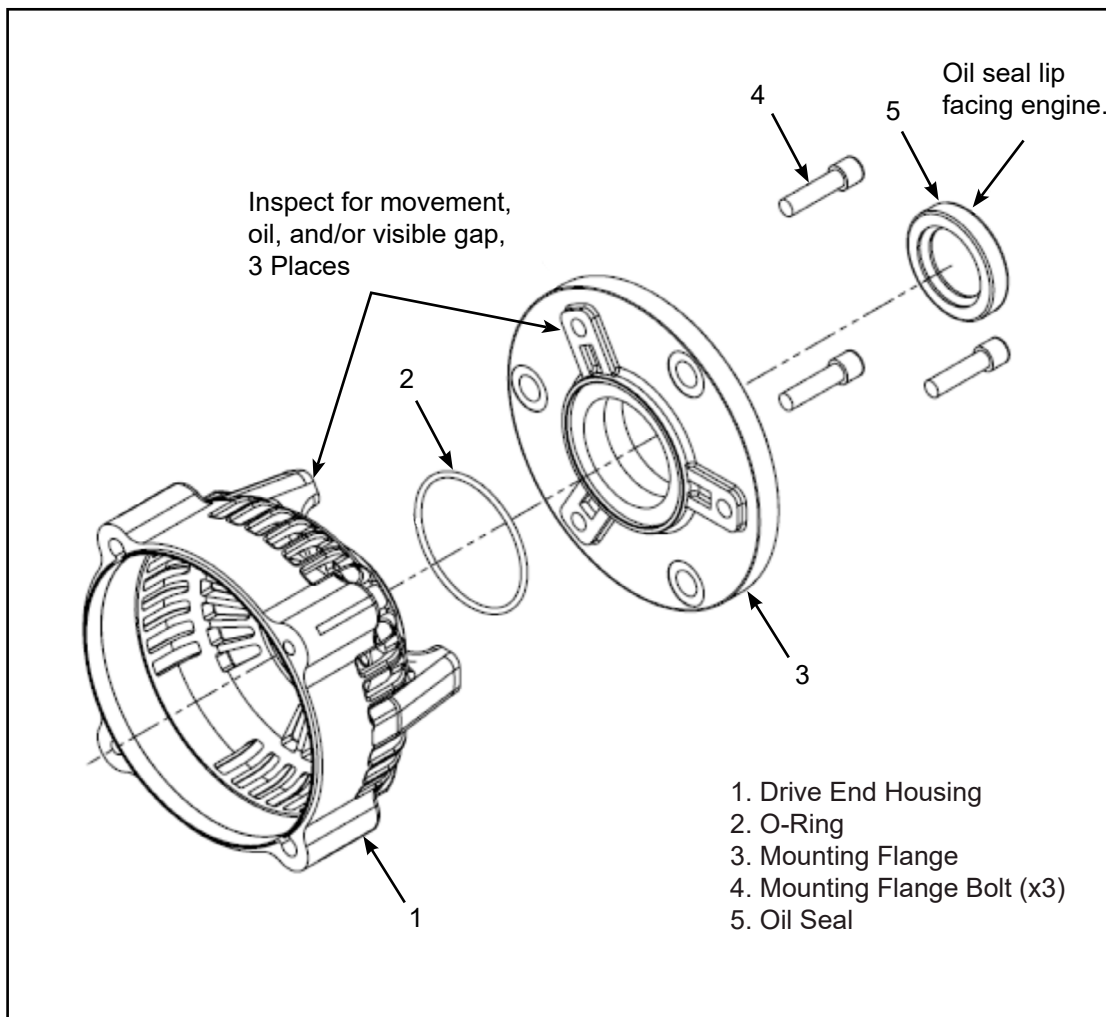

Figure 1 - Alternator Mounting Flange

Alert Service Bulletin

Alert Service Bulletin No. 097

Alternator Mounting Flange Inspection

Aircraft Make	Aircraft Model Series
AD Holdings, Inc.	T-21I with STC SA10921SC installed
Aircraft Parts & Development Corp.	A-3 with STC SA10921SC installed
Aerodifusion, S.L.	D-1190S with STC SA10921SC installed
American Champion Aircraft Corp.	7EC, 7ECA, 7FC, 7JC, S7EC, 402 with STC SA10921SC installed
Burl A. Rogers	15AC, S15AC with STC SA10921SC installed
Textron Aviation Inc.	45 (YT-34), 35, A35, B35, C35, E35, F35, G35, D35, 35R, with STC SA10921SC installed (Equipped with E225-8 Engine.)
All American Aircraft, Inc.	10A with STC SA10921SC installed
Textron Aviation Inc.	150, A, B, C, D, E, F, G, H, J, K, L, M, A150K, A150L, A150M with STC SA10921SC installed 120, 140, A, 170, A, B, 172, A, B, C, D, E, F, G, H, R172F, R172G, R172H with STC SA10921SC installed
Commonwealth Aircraft, Inc.	185 with STC SA10921SC installed
Edward Scott Kearns	Trojan A-2 with STC SA10921SC installed
FS 2001 Corp	J5A (Army L-4F), Equipped with C75-12 Engine with STC SA10921SC installed
Swift Museum Foundation, Inc.	GC-1A, -1B with STC SA10921SC installed
Goodyear Aircraft Corporation	GA-22A with STC SA10921SC installed
Helio Aircraft Corporation	15A, Equipped with C145-2 Engine. with STC SA10921SC installed
Avion Jodel	150, DR-1050 D-1190 with STC SA10921SC installed
Goodearth Organization (The Don Luscombe Aviation History Foundation, Inc).	8E, 8F, T-8F with STC SA10921SC installed
Maule Aerospace Technology, Inc.	Bee Dee M-4, M-4, -4C, -4S, -4T, M-4-210, M-4-210C, M-4-210S, M-4-210T with STC SA10921SC installed
MICCO Aircraft Company, Inc.	MAC-125C, MAC-145 with STC SA10921SC installed
Sierra Hotel Aero, Inc.	Navion (Army L-17A), Navion A (Army L-17B & L-17C). with STC SA10921SC installed
Piper Aircraft, Inc.	J3C-65, -65S (Army L-4, L-4A, L-4B Navy NE-1, L-4H, L-4J Navy NE-2), Equipped with C75-12, J4A, Equipped with C85-12 Engine, J4E (Army L-4E), Equipped with C75-12 Engine, PA-18, -18S, PA-19, -19S Equipped with C90-12F Engine with STC SA10921SC installed

Table-1 - Alternator/Aircraft Effectivity (cont'd)

Alert Service Bulletin

Alert Service Bulletin No. 097

Alternator Mounting Flange Inspection

Aircraft Make	Aircraft Model Series
JGS Properties Inc. (Quartz Mountain Aerospace, Inc.)	11A with STC SA10921SC installed
S.O.C.A.T.A. - Groupe Aerospatiale	Rallye MS880B, MS885, 100S with STC SA10921SC installed
Superior Aircraft Company	Culver V, V2 with STC SA10921SC installed
Taylorcraft 2000, LLC	19, BC12D-4-85, BCS12D-4-85 with STC SA10921SC installed
Thomas H. McClish	B85C with STC SA10921SC installed
Univair Aircraft Corporation	415-C, -CD, Equipped with C75-12, C75-12F, C85-12, or C85-12F Engine), 415-D, E, G, F-1, F-1A, A-2, A2-A, M10 with STC SA10921SC installed

(cont'd) Table-1 - Alternator/Aircraft Effectivity

Alert Service Bulletin

Alert Service Bulletin No. 097

Alternator Mounting Flange Inspection

3. Accomplishment Instructions

WARNING: THIS PROCEDURE MUST BE PERFORMED BY COMPETENT AND QUALIFIED PERSONNEL WHO ARE FAMILIAR WITH ENGINE AND AIRFRAME MAINTENANCE THAT IS SPECIFIC TO THE ENGINE FUEL SYSTEM. FAILURE TO DO SO MAY RESULT IN ECONOMIC LOSS, EQUIPMENT DAMAGE, AND/OR PHYSICAL INJURY.

CAUTION 1: DO NOT USE OBSOLETE OR OUTDATED INFORMATION. PERFORM ALL INSPECTIONS OR WORK IN ACCORDANCE WITH THE MOST RECENT REVISION OF THIS ALERT SERVICE BULLETIN AND THE APPLICABLE AIRCRAFT, ENGINE AND/OR THE HET P/N 200201-0000 MAINTENANCE MANUAL. INFORMATION CONTAINED IN THESE MANUALS OR THIS ALERT SERVICE BULLETIN MAY BE SIGNIFICANTLY CHANGED FROM EARLIER REVISIONS. FAILURE TO COMPLY WITH THE ALERT SERVICE BULLETIN OR THE USE OF OBSOLETE INFORMATION MAY CREATE AN UNSAFE CONDITION THAT MAY RESULT IN DEATH, SERIOUS BODILY INJURY, AND/OR SUBSTANTIAL PROPERTY DAMAGE. REFER TO THE PLANE POWER WEBSITE (WWW.PLANEPOWER.AERO) FOR THE MOST RECENT REVISION LEVEL OF THIS ALERT SERVICE BULLETIN.

CAUTION 2: DO NOT DEPEND ON THIS ALERT SERVICE BULLETIN FOR GAINING ACCESS TO THE ENGINE OR ALTERNATOR. ACCESS REQUIRES THE USE OF THE APPLICABLE MANUFACTURER'S MAINTENANCE MANUALS OR SERVICE INSTRUCTIONS. IN ADDITION, ANY PREFLIGHT OR IN FLIGHT OPERATIONAL CHECKS REQUIRE USE OF THE APPROPRIATE AFM OR POH.

A. Alternator Identification

- (1) If positive identification of the alternator model and serial number can be made through the engine or aircraft documentation, and the alternator **is** affected per 1.A, continue to 3.B., Corrective Action. If the alternator is **not** affected, continue to 3.D.(2), Maintenance Record.
- (2) If positive identification cannot be made through engine or aircraft documentation, gain access and locate the data tag on the alternator to verify the alternator effectivity.
 - (a) If the unit **is** affected, continue to section 3.B., Corrective Action.
 - (b) If the unit is **not** affected, install any components that were removed to gain access in accordance with the latest engine/airframe service instructions or maintenance manual. Continue to 3.D.(2), Maintenance Record.

B. Corrective Action

- (1) If a loose condition or oil leak is **not** found
 - (a) Remove affected alternator per applicable aircraft engine and airframe service instructions or maintenance manual.
 - (b) Remove and discard one of three flange bolts (4) securing the alternator to the mounting flange.
 - (c) Apply a mild solvent to a non-metallic bristle brush and remove oil/grease and any cured threadlocker present in the drive end housing threads. Ensure debris does not enter the alternator housing.
 - (d) Apply LOCTITE® 272 threadlocker to one of three drive end housing (1) threads and install one new flange bolt (4) to snug condition.
 - (e) Repeat steps (b) thru (d) for remaining two flange bolts.

Alert Service Bulletin

Alert Service Bulletin No. 097

Alternator Mounting Flange Inspection

- (f) Torque alternator mounting flange bolts to 85-90 in-lbs.
 - (g) Inspect alternator drive coupling per manufacturer's instructions.
 - (h) Install the alternator onto the engine per applicable aircraft engine and airframe service instructions or maintenance manual. Continue to 3.C, Return to Service.
- (2) If a loose condition or oil leak **is** found
- (a) Remove affected alternator per applicable aircraft engine and airframe service instructions or maintenance manual.
 - (b) Remove the alternator drive coupling from the alternator per manufacturer's instructions.
 - (c) Remove and discard three mounting flange bolts (4) and separate the mounting flange (3) from the alternator drive end housing (1).
 - (d) Inspect the mounting flange (3) for damage, replace as required.
 - (e) Using an arbor press and adequate push tool, push the oil seal (5) from the mounting flange (3) and discard the oil seal. Manufacture push tool per dimensions in **Figure 2**.
- NOTE:** Push the oil seal from the engine side of the mounting flange (3). See **Figure 3**.
- (f) Clean oil seal bore of mounting flange with mild solvent and non-metallic bristle brush and shop towel. Dry with shop air.
 - (g) Using an arbor press and adequate push tool, press new oil seal (5) from alternator side of the mounting flange (3) with oil seal (5) lip facing down (toward engine). Press flush to .015 in. below flush with oil seal bore. See **Figure 3**, Oil Seal Orientation.
 - (h) Lubricate lip of oil seal (5) with engine oil.
 - (i) Remove and discard the O-ring (2) from the drive end housing (1).
 - (j) Apply a mild solvent to a non-metallic bristle brush and remove oil/grease and any cured threadlocker present in the drive end housing (1) threads. Ensure debris does not enter the alternator housing.
 - (k) Install new O-ring (2) onto the drive end housing (1). Lubricate O-ring with engine oil.
 - (l) Apply LOCTITE® 272 threadlocker to the threads of the drive end housing (1).
 - (m) Install the alternator mounting flange (3) onto the alternator drive end housing (1). Secure with three new mounting flange bolts (4) to snug condition.
 - (n) Torque alternator mounting flange bolts (4) to 85-90 in-lbs.
 - (o) Reinstall the alternator drive coupling onto the alternator and perform any required inspections per manufacturer's instructions.
 - (p) Install alternator onto the engine per applicable aircraft engine and airframe service instructions and maintenance manual. Continue to 3.C, Return to Service.

Alert Service Bulletin

Alert Service Bulletin No. 097

Alternator Mounting Flange Inspection

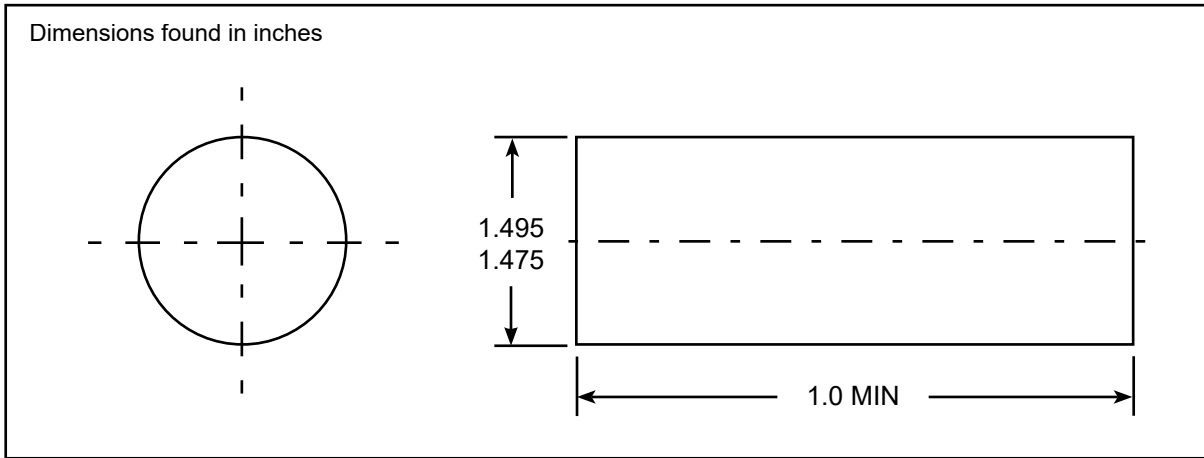

Figure 2 - Oil Seal Push Tool

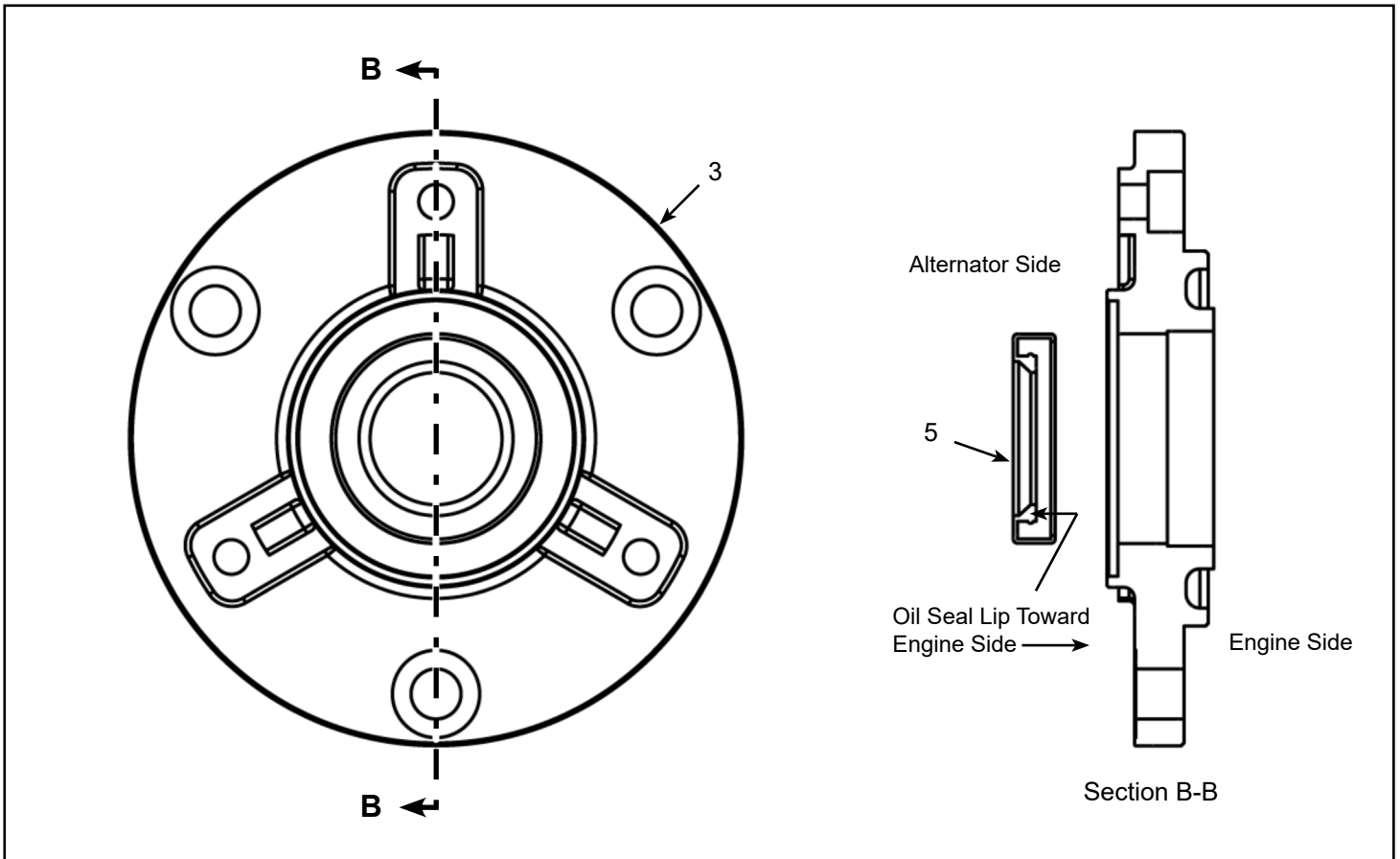

Figure 3 - Oil Seal Orientation

Alert Service Bulletin

Alert Service Bulletin No. 097

Alternator Mounting Flange Inspection

C. Return to Service

- (1) Perform the recommended alternator system set up and functional tests in accordance with the appropriate aircraft maintenance manual, engine service instructions, and operational tests in the AFM or POH.

D. Maintenance Record

- (1) For affected alternator continuing in-service, make an engine logbook entry to indicate compliance with this Alert Service Bulletin noting when the next inspection is due.
- (2) For terminating action, make an engine logbook entry to indicate compliance with this Alert Service Bulletin.

4. Contact Information

A. Contact HET Product Support for all communications regarding the technical content of this Alert Service Bulletin.

- (1) Phone +1.334.386.5400 (Option 2)
- (2) Fax +1.334.386.5450.
- (3) E-mail at techsupport@HartzellEngineTech.com.
- (4) Address

Hartzell Engine Tech LLC
2900 Selma Highway,
Montgomery, AL 36108
USA

ALERT SERVICE BULLETIN APPENDIX

ALERT SERVICE BULLETIN No. 097

Alternator Mounting Flange Inspection

1. Eligibility:

- A. Alternator part numbers listed in Table 1 of Alert Service Bulletin (ASB) 097 shipped by Hartzell Engine Tech LLC (HET) between 01/01/2019 and 01/01/2023 are affected.
- B. Serial numbers H-T010001 thru H-X012176 and H-1010001 thru H-1019999 are affected.

2. Commercial Assistance Program:

The following will be provided with the submission of a completed ASB 097 Claim Form, copies of invoices showing breakdown of material and labor charges, and log book entries. **Any commercial assistance or other consideration shall expire twelve (12) calendar months from the original published date of ASB No. 097.**

- A. Required material listed in section 2 of ASB 097.
- B. Labor for inspection, removal, & installation of an affected aircraft alternator will be paid at a shop rate of \$85 per hour, not to exceed US\$170 per affected alternator.
 - (1) Up to two (2) man hours of labor are needed for removal and replacement of the alternator assembly.

3. Commercial Assistance ADMINISTRATION:

- A. Complete the ASB 097 Claim Form attached to this appendix.
 - (1) Mail, e-mail, or fax the ASB 097 Claim Form to the attention of Product Support as indicated on the ASB Claim Form.
- B. Upon receipt of the ASB Claim Form, Hartzell Engine Tech LLC will:
 - (1) Ship the required material in accordance with section 2 of ASB 097 to the service provider indicated.
 - (2) The service provider must return proof of service within thirty (30) days or the service provider shall be invoiced for the HET supplied materials.
- C. For labor and parts listed in section 2:
 - (1) Aircraft/engine service facility or owner must submit an invoice up to the amount specified in section 2, copies of logbook entries, and a completed ASB 097 Claim Form for reimbursement (*May be a copy of the original form provided*).

ALERT SERVICE BULLETIN APPENDIX

ALERT SERVICE BULLETIN No. 097

Alternator Mounting Flange Inspection

4. WARRANTY STATEMENT:

- A. The sole warranty for the actions of ASB 097 are contained in the HET Limited Warranty Policy issued with the purchase of each new/overhauled alternators (see terms and conditions therein).
- B. Commercial assistance may apply as stated in this Appendix.
- C. Issuance of ASB 097 in no way constitutes an implied or expressed warranty of any kind.
- D. This publication does not imply or state any responsibility for the workmanship of any person or entity performing work or maintenance on the engine or aircraft electrical system.

5. CONTACT INFORMATION:

- A. Contact HET Product Support for all communications regarding the technical content of this Alert Service Bulletin.
 - (1) Phone +1.334.386.5400 (Option 2)
 - (2) Fax +1.334.386.5410
 - (3) E-mail at techsupport@Hartzell.aero
 - (4) Address
 - Hartzell Engine Tech LLC
 - 2900 Selma Highway,
 - Montgomery, AL 36108
 - USA

ALERT SERVICE BULLETIN APPENDIX

ALERT SERVICE BULLETIN No. 097

Alternator Mounting Flange Inspection

ASB 097 CLAIM FORM

Owner information

Name: _____ Date: _____ Tel: _____ Fax: _____

Company Name: _____ E-mail: _____

Address: _____

City: _____ State: _____ Postal Code: _____

Country: _____

Aircraft/Engine Service Facility information

Name: _____ Date: _____ Tel: _____ Fax: _____

Company Name: _____ E-mail: _____

Address: _____

City: _____ State: _____ Postal Code: _____

Country: _____

Aircraft Mfg: _____ Model: _____ Time in Service: _____ S/N: _____

Engine: _____ Model: _____ Time in Service: _____ S/N: _____

Component Information

Nomenclature: Alternator Assembly _____ Part Number: _____

Serial Number: _____ (Alternator) Date Removed: _____

Part Time in Service: _____ (Alternator) Original Date Installed: _____

For RMA Number

Send this ASB 097 Claim Form to:

Hartzell Engine Tech Product Support

Fax: +1.334.386.5410

E-mail: techsupport@hartzell.aero

RMA Number:

(write in HET assigned RMA number)

Hartzell Use Only - do not write below this line.

Warranty No: _____ Authorized by: _____